

2 April 2026

Our Ref: 5193971
File Ref: EXE2026/0002
Enquiries: Luke Acreman

Mark and Ruth Connell
C/ - Rapid Building Approvals
Attn: Jacob Monaghan
323 Ingham Road
GARBUTT QLD 4820

Sent via email: approvals@rapidapprovals.com.au

Dear Greg and Rosalind,

Exemption Certificate

(Given under Section 74 of the *Queensland Heritage Act 1992*)

The application for an Exemption Certificate (Heritage Exemption Certificate) to carry out the development described below, is approved with conditions under Section 74 of the *Queensland Heritage Act 1992*.

This Heritage Exemption Certificate attaches to the premises. Any person, including the owners, owners' successors in title and occupiers of the premises, may carry out development permitted by this exemption certificate and is bound by the conditions.

This Heritage Exemption Certificate only applies to development substantially started within 4 years of this decision. Note that the *Queensland Heritage Act 1992* does not provide for extensions of time to Exemption Certificates. If development does not substantially start within 4 years of this decision, this approval will lapse and a new application will need to be made.

Terms and phrases used in this document are defined principally in the *Queensland Heritage Act 1992*, and in the *Planning Act 2016* and its Regulation.

NOTE:

- This Heritage Exemption Certificate does not give approval for works under the *Building Act 1975* and the *Plumbing and Drainage Act 2018*.

Applicant details

Applicant name: Mark Connell and Ruth Connell (C/- Rapid Building Approvals (Jacob Monaghan))

Location details

Street address: 16 Park Street, Charters Towers City
Real property description: Lot 3 on MPH20376

PO Box 189 Charters Towers Qld 4820

ADMINISTRATION: 12 Mosman Street Charters Towers Qld 4820 Australia

PH. (07) 4761 5300 | **F.** (07) 4761 5344 | **E.** mail@charters Towers.qld.gov.au | **ABN.** 67 731 313 583

www.charters Towers.qld.gov.au



Development to which the Exemption Certificate relates

Application number:	EXE2026/0002
Local heritage place:	135 Mosman Street, Charters Towers City
Development proposed:	Building work
Description of development:	Construction of a new Class 10a shed at the rear of the property
Reason for giving Exemption Certificate:	The proposed development has been assessed as having no more than a minor detrimental impact on the cultural heritage significance of the place.

Approved plans and documents

Development stated in this Exemption Certificate must be generally in accordance with the below approved plans/documents:

Drawing title:	Prepared by:	Date:	Reference no:	Revision:
- (Site Plan)	Rapid Building Approvals	20/02/2026	-	-
- (Foundation Plan and Member Layout)	Fair Dinkum Builds	19/02/2026	Sheet 1 of 6	-
- (Elevations)	Fair Dinkum Builds	19/02/2026	Sheet 2 of 6	-

The approved plans and/or documents in relation to this approval are included as an attachment.

Conditions of approval

General		
No.	Condition	Condition Timing
1.	<p>Scope of the development. Carry out the development as described in the application received on 20 February 2026. In the case of a discrepancy between application documents and conditions, conditions take precedence. <i>(Reason - To ensure development is carried out as approved)</i></p>	At all times.
2.	<p>Keep a copy of the approval on site A copy of this exemption certificate and a copy of any documents that describe the approved development must be retained at the Local heritage place. <i>(Reason – To facilitate the monitoring of development for compliance purposes)</i></p>	For the duration of the development.
3.	<p>Photograph effect of development Submit photographs of the area of development, both before and after the development is completed to Charters Towers Regional Council at development@charters Towers.qld.gov.au. The submission must state the address of the place, the application number, and condition number 3. <i>(Reason – To facilitate the monitoring of development for compliance purposes and ensure change is adequately recorded)</i></p>	Within 10 business days of completion of the development

Date: 2 April 2026
Our Ref: 5193971

General		
No.	Condition	Condition Timing
4.	<p>Protect the local heritage place from damage Protect the existing features of the local heritage place from incidental damage and maintain protective measures to ensure the development does not result in damage to, or deterioration of, the Local heritage place caused by weather, fire, vandalism, insects or other factors. <i>(Reason - To ensure the cultural heritage values of the Local heritage place are appropriately recognised and managed)</i></p>	For the duration of the development.
5.	<p>Extent of works applicable under the HEC The works included in this HEC relate to the construction of a shed at the rear of the lot, the design and siting of which must be generally in accordance with the approved plans and documents. <i>(Reason - To ensure the cultural heritage values of the Local heritage place are appropriately recognised and managed)</i></p>	For the duration of the development.
6.	<p>Report any damage to the local heritage place that occurs During development, should damage occur to any features of the Local heritage place report such incidents immediately to the Planner at development@chartersowers.qld.gov.au. <i>(Reason - To ensure the cultural heritage values of the Local heritage place are appropriately recognised and managed)</i></p>	Immediately, should damage occur.
7.	<p>Permit access to the local heritage place Permit access to the local heritage place by Charters Tower Regional Council officers if requested. <i>(Reason – To facilitate the monitoring of development for compliance purposes)</i></p>	For the duration of the development.

Should you wish to discuss this matter, please contact Council's Planner on (07) 4761 5300 or via email development@chartersowers.qld.gov.au.

Yours faithfully



Timna Green
Manager Planning & Development

Enc. Approved Plans



SITE PLAN - NEW SHED - 135 MOSMAN STREET,
CHARTERS TOWERS

1.5M FROM BOUNDARY



3M FROM HOUSE

3M FROM SEWER

The design and detail shown on these drawings are applicable to this project only and may not be reproduced in whole or any part or be used for any other purpose without the written permission of FBHS (Aust) Pty Limited (FBHS) with whom copyright resides. The local distributor or franchisee you are dealing with is an authorised independent distributor or franchisee of FBHS' products and they enter into agreements with their customers on their own behalf and not as an agent for FBHS.

IF IN DOUBT, ASK.

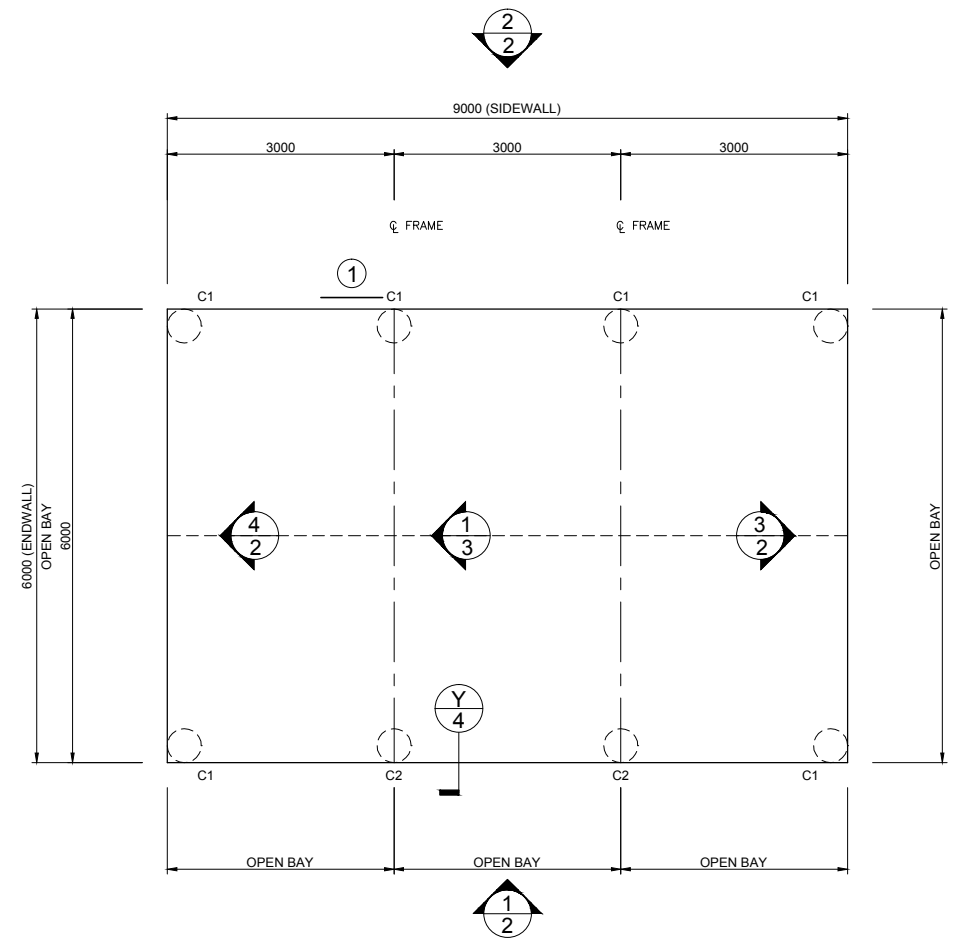

1 FOUNDATION PLAN AND MEMBER LAYOUT
SCALE: 1 = 100

DO NOT SCALE THIS DRAWING. USE FIGURED DIMENSIONS ONLY. ALL DIMENSIONS TO BE VERIFIED ON SITE.

APPROVED PLAN
CHARTERS TOWERS
Planning and Development
DATE: 2 April 2026
APPLICATION: EXE2026-0002

MEMBER LEGEND

C1	C15024
C2	C15019

1 OF 6
SHEET
JOB NO. CHRT100508
DATE 19/2/2026
CHECKED TM
DRAWN FDB

STEEL BUILDING BY (CONTACT)
FAIR DINKUM BUILDS CHARTERS TOWERS
FOR 0419708861
AT **CONNELL (MARK)**
135 MOSMAN STREET
CHARTERS TOWERS



NORTHERN CONSULTING engineers
Civil & Structural Engineers
50 Punari Street
Currajong, Qld 4812
Fax: 07 4725 5850
Email: design@nceng.com.au
ABN 341 008 173 56

Registered Chartered Professional Engineer
Registered Professional Engineer (Civil & Structural) QLD
Registered Certifying Engineer (Structural) N.T.
Registered Engineer - (Civil) VIC
Registered Engineer - (Civil) TAS

Regn. No. 2558980
Regn. No. 9985
Regn. No. 116373ES
Regn. No. PE0002216
Regn. No. CC5648M

Mr Timothy Roy Messer BE MIEAust RPEQ
Signature *T. Messer*
Date 19/2/2026
Registered on the NPER in the areas of practice
of Civil & Structural National Professional
Engineers Register

The design and detail shown on these drawings are applicable to this project only and may not be reproduced in whole or any part or be used for any other purpose without the written permission of FBHS (Aust) Pty Limited (FBHS) with whom copyright resides. The local distributor or franchisee you are dealing with is an authorised independent distributor or franchisee of FBHS' products and they enter into agreements with their customers on their own behalf and not as an agent for FBHS.

ROOF PURLINS PER MEMBER SCHEDULE ON SHEET 5

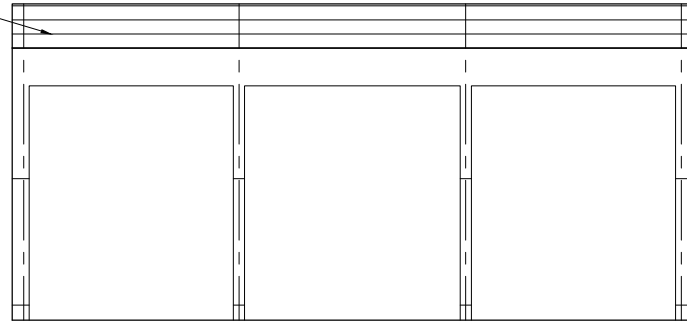

1 SIDEWALL EXTERIOR ELEVATION
2 SCALE: 1 = 100

ROOF PURLINS PER MEMBER SCHEDULE ON SHEET 5

SIDEWALL GIRTS PER MEMBER SCHEDULE ON SHEET 5

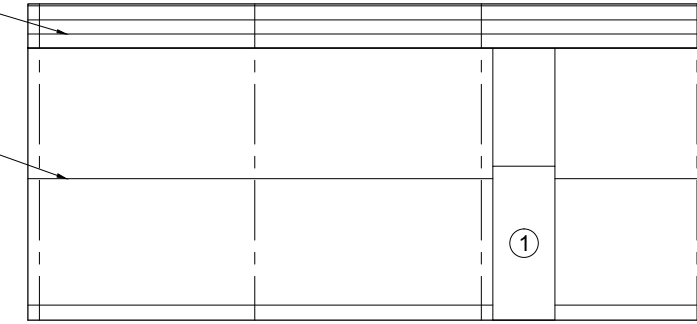

2 SIDEWALL EXTERIOR ELEVATION
2 SCALE: 1 = 100

ROOF PURLINS PER SCHEDULE

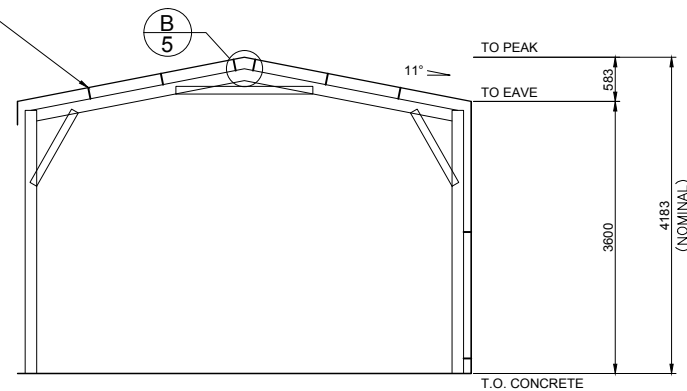

4 ENDWALL INTERIOR ELEVATION
2 SCALE: 1 = 100

ROOF PURLINS PER SCHEDULE

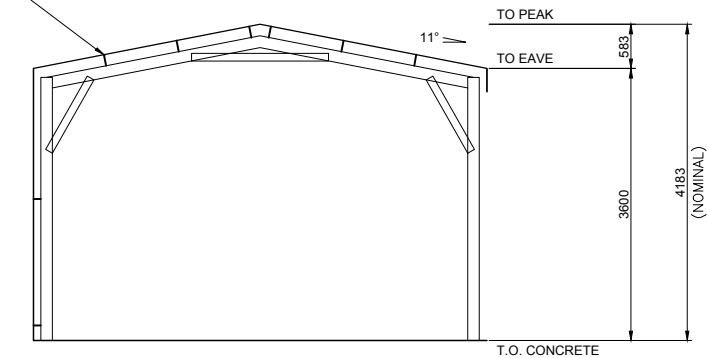

3 ENDWALL INTERIOR ELEVATION
2 SCALE: 1 = 100

DIAGONAL X BRACING NOT REQUIRED IN THIS BUILDING.

CLADDING DIAPHRAGM SUFFICIENT. FLY BRACING IS INCLUDED TO BE PLACED ON EVERY SECOND PURLIN AND GIRT ON ENDWALL MULLIONS, INTERNAL COLUMNS AND INTERNAL RAFTERS.



2 OF 6	SHEET	JOB NO. CHRT100508	DATE 19/2/2026	CHECKED TM	DRAWN FDB
	STEEL BUILDING BY (CONTACT) FAIR DINKUM BUILDS CHARTERS TOWERS FOR 0419708861 CONNELL (MARK) AT 135 MOSMAN STREET CHARTERS TOWERS				

STEEL BUILDING BY (CONTACT)
FAIR DINKUM BUILDS CHARTERS TOWERS
FOR
0419708861
CONNELL (MARK)
AT
135 MOSMAN STREET
CHARTERS TOWERS

NORTHERN CONSULTING engineers
Civil & Structural Engineers
50 Punari Street
Currajong, Qld 4812
Fax: 07 4725 5850
Email: design@nceng.com.au
ABN 341 008 173 56

Registered Chartered Professional Engineer
Registered Professional Engineer (Civil & Structural) QLD
Registered Certifying Engineer (Structural) N.T.
Registered Engineer - (Civil) VIC
Registered Engineer - (Civil) TAS

Regn. No. 2558980
Regn. No. 9985
Regn. No. 116373ES
Regn. No. PE0002216
Regn. No. CC5648M

Mr Timothy Roy Messer BE MIEAust RPEQ

Signature *T. Messer*

Date 19/2/2026

Registered on the NPER in the areas of practice
of Civil & Structural National Professional
Engineers Register

Planning Act 2016

Reprint current from 2 August 2024

[Chapter 6](#) > Part 1

Part 1 Appeal rights

229 Appeals to tribunal or P&E Court

- (1) [Schedule 1](#) states—
 - (a) matters that may be appealed to—
 - (i) either a tribunal or the P&E Court; or
 - (ii) only a tribunal; or
 - (iii) only the P&E Court; and
 - (b) the person—
 - (i) who may appeal a matter (the *appellant*); and
 - (ii) who is a respondent in an appeal of the matter; and
 - (iii) who is a co-respondent in an appeal of the matter; and
 - (iv) who may elect to be a co-respondent in an appeal of the matter.
- (2) An appellant may start an appeal within the appeal period.
- (3) The *appeal period* is—
 - (a) for an appeal by a building advisory agency—10 business days after a decision notice for the decision is given to the agency; or
 - (b) for an appeal against a deemed refusal—at any time after the deemed refusal happens; or
 - (c) for an appeal against a decision of the Minister, under [chapter 7, part 4](#), to register premises or to renew the registration of premises—20 business days after a notice is published under [section 269\(3\)\(a\)](#) or (4); or
 - (d) for an appeal against a decision of the Minister, under [chapter 7, part 4](#), to amend the registration of premises to include additional land in the affected area for the premises—20 business days after the day a notice is published under [section 269A\(2\)\(a\)](#); or
 - (e) for an appeal against an infrastructure charges notice—20 business days after the infrastructure charges notice is given to the person; or
 - (f) for an appeal about a deemed approval of a development application for which a decision notice has not been given—30 business days after the

applicant gives the deemed approval notice to the assessment manager; or

- (g) for an appeal relating to the Plumbing and Drainage Act 2018—
 - (i) for an appeal against an enforcement notice given because of a belief mentioned in the Plumbing and Drainage Act 2018, section 143(2)(a) (i), (b) or (c)—5 business days after the day the notice is given; or
 - (ii) for an appeal against a decision of a local government or an inspector to give an action notice under the Plumbing and Drainage Act 2018—5 business days after the notice is given; or
 - (iii) for an appeal against a failure to make a decision about an application or other matter under the Plumbing and Drainage Act 2018—at anytime after the period within which the application or matter was required to be decided ends; or
 - (iv) otherwise—20 business days after the day the notice is given; or
- (h) for any other appeal—20 business days after a notice of the decision for the matter, including an enforcement notice, is given to the person.

Note—

See the P&E Court Act for the court's power to extend the appeal period.

- (4) Each respondent and co-respondent for an appeal may be heard in the appeal.
- (5) If an appeal is only about a referral agency's response, the assessment manager may apply to the tribunal or P&E Court to withdraw from the appeal.
- (6) To remove any doubt, it is declared that an appeal against an infrastructure charges notice must not be about—
 - (a) the adopted charge itself; or
 - (b) for a decision about an offset or refund—
 - (i) the establishment cost of trunk infrastructure identified in a LGIP; or
 - (ii) the cost of infrastructure decided using the method included in the local government's charges resolution.

230 Notice of appeal

- (1) An appellant starts an appeal by lodging, with the registrar of the tribunal or P&E Court, a notice of appeal that—
 - (a) is in the approved form; and
 - (b) succinctly states the grounds of the appeal.
- (2) The notice of appeal must be accompanied by the required fee.
- (3) The appellant or, for an appeal to a tribunal, the registrar, must, within the service period, give a copy of the notice of appeal to—
 - (a) the respondent for the appeal; and
 - (b) each co-respondent for the appeal; and
 - (c) for an appeal about a development application under schedule 1, section 1, table 1, item 1—each principal submitter for the application whose submission has not been withdrawn; and

- (d) for an appeal about a change application under schedule 1, section 1, table 1, item 2—each principal submitter for the application whose submission has not been withdrawn; and
 - (e) each person who may elect to be a co-respondent for the appeal other than an eligible submitter for a development application or change application the subject of the appeal; and
 - (f) for an appeal to the P&E Court—the chief executive; and
 - (g) for an appeal to a tribunal under another Act—any other person who the registrar considers appropriate.
- (4) The *service period* is—
- (a) if a submitter or advice agency started the appeal in the P&E Court—2 business days after the appeal is started; or
 - (b) otherwise—10 business days after the appeal is started.
- (5) A notice of appeal given to a person who may elect to be a co-respondent must state the effect of subsection (6).
- (6) A person elects to be a co-respondent to an appeal by filing a notice of election in the approved form—
- (a) if a copy of the notice of appeal is given to the person—within 10 business days after the copy is given to the person; or
 - (b) otherwise—within 15 business days after the notice of appeal is lodged with the registrar of the tribunal or the P&E Court.
- (7) Despite any other Act or rules of court to the contrary, a copy of a notice of appeal may be given to the chief executive by emailing the copy to the chief executive at the email address stated on the department’s website for this purpose.

231 Non-appealable decisions and matters

- (1) Subject to this chapter, section 316(2), schedule 1 and the P&E Court Act, unless the Supreme Court decides a decision or other matter under this Act is affected by jurisdictional error, the decision or matter is non-appealable.
- (2) The *Judicial Review Act 1991*, part 5 applies to the decision or matter to the extent it is affected by jurisdictional error.
- (3) A person who, but for subsection (1) could have made an application under the *Judicial Review Act 1991* in relation to the decision or matter, may apply under part 4 of that Act for a statement of reasons in relation to the decision or matter.
- (4) In this section—

decision includes—

 - (a) conduct engaged in for the purpose of making a decision; and
 - (b) other conduct that relates to the making of a decision; and
 - (c) the making of a decision or the failure to make a decision; and
 - (d) a purported decision; and
 - (e) a deemed refusal.

non-appealable, for a decision or matter, means the decision or matter—

- (a) is final and conclusive; and
- (b) may not be challenged, appealed against, reviewed, quashed, set aside or called into question in any other way under the *Judicial Review Act 1991* or otherwise, whether by the Supreme Court, another court, any tribunal or another entity; and
- (c) is not subject to any declaratory, injunctive or other order of the Supreme Court, another court, any tribunal or another entity on any ground.

232 Rules of the P&E Court

- (1) A person who is appealing to the P&E Court must comply with the rules of the court that apply to the appeal.
- (2) However, the P&E Court may hear and decide an appeal even if the person has not complied with rules of the P&E Court.